

Experimental Instructions

for

“Competition and Well-Being”

Jordi Brandts*

Arno Riedl†

Frans van Winden‡

*Institut d'Anàlisi Econòmica (CSIC), Campus UAB, Bellaterra, Barcelona, Spain.

†Tinbergen Institute and University of Amsterdam, CREED, Faculty of Economics and Econometrics, Roetersstraat 11, NL-1018 WB Amsterdam, The Netherlands, e-mail: a.m.riedl@uva.nl

‡Tinbergen Institute and University of Amsterdam, CREED, Faculty of Economics and Econometrics, Roetersstraat 11, NL-1018 WB Amsterdam, The Netherlands, e-mail: f.a.a.m.vanwinden@uva.nl

This is a translation. The original instructions are in Dutch. The text in boldface-italics was not part of the original instructions.

Welcome to this experiment on decision-making. In this experiment you can earn money. How much you earn - in addition to your show-up fee of 5 guilders - depends on your own decisions and the decisions of other participants.

The experiment consists of three parts. In each part you will be able to earn points. Your earnings in each part are independent of your earnings in the other parts. At the end of the experiment you will be privately paid your earnings in cash, according to the conversion rate:

$$1000 \text{ points} = 5 \text{ guilders.}$$

You will now get an explanation of the first part. The instructions for the second part will be given to you after you have finished the first part and the instructions for the third part after you have finished the second part. After the experiment we will ask you to fill in a short questionnaire. After that the payments will be made.

Please raise your hand if you have a question. We will then come to you to answer it.

Explanation part I

In part I of the experiment you will be asked to make a choice. This choice concerns the allocation of an amount (points) to yourself and to a randomly chosen other participant. You have received from us a printout of the computer screen for part I. Please put this printout in front of you. With the help of this printout we will explain which choices you can make.

On the screen you see a circle. By choosing a point on this circle you will make a decision on allocating an amount to yourself and an amount to a completely randomly chosen other participant in the experiment. This other participant will be chosen at random by the computer. Every point on the circle corresponds to an amount that either will be added to (+) or deducted from (−) your earnings and an amount that either will be added to (+) or deducted from (−) the earnings of the participant you are connected with. By making your choice you can make yourself and the other earn more or less.

You can click on a point on the circle by using the mouse. You will then see an arrow that indicates the choice that you made. Furthermore, below the circle, the allocated

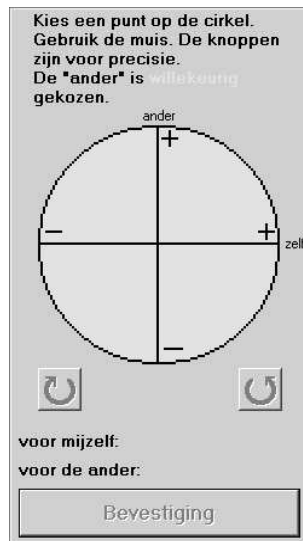

Translation:
*Choose a point on the
 circle.
 Use the mouse. The but-
 tons are for precision.
 The "other" is arbitrar-
 ily chosen.*

*for myself:
 for the other:
 Confirmation*

amounts that correspond to the chosen point on the circle will be shown. Next to the phrase “for myself” you will see the amount you are allocating to yourself and next to “for the other” you will be see the amount that you are allocating to the other. In order to adjust your choice you can click on another point on the circle. You can also use the buttons under the circle. With these buttons you can pinpoint your choice, which means that you can turn the small arrow a bit further “clockwise” (left button) or “counter-clockwise” (right button). When you are satisfied with the choice you have made please click on the “confirmation” button. You will then see a “last chance” to change your choice on the screen. Click yes if you do not want to change your choice anymore.

Your earnings will be determined by your own decision and the decision of the other randomly chosen participant with whom you are connected. This other participant will have to make a similar decision. Your earnings from this part of the experiment will therefore equal the sum of the amount that you are assigning to yourself and the amount that the other participant will be assigning to you.

Note: An amount can be positive, but can also be negative. In the latter case the amount will be at the expense of the person that it is meant for.

You will now first go through a practice round. You cannot earn any money in this practice round. After that you will have another opportunity to ask questions before part I will start.

If you have any questions at this stage please raise your hand.

The following part of the instructions were given only after everybody had finished the first part. What follows are the instructions for part II in the NCC.

Explanation for Part II

In this part of the experiment each participant will form a pair with another participant. Each pair consists of a “type A” and a “type B” participant. Before part II will start, pairs will be formed randomly with the help of the computer and the participants within each pair will be labeled as type A or type B. Neither the pair of which you are going to be part of nor your type within this pair will change during this part of the experiment. Which type you are going to be will be announced on your computer screen before the start of part II.

Part II consists of 30 rounds. In each round you have to make a decision, independently of your type.

Note: During all 30 rounds the other participant in your pair will remain the same person and the type of a participant will not change.

Decisions (in a round)

Type A as well as type B have to choose between the two alternatives “0” and “10”.

Earnings

Regardless of whether you are a type A or a type B your earnings will depend on the choice between 0 and 10 you and your partner make. There are four possibilities:

your choice	partner's choice	your earnings	partner's earnings
0	0	160 points	160 points
0	10	410 points	40 points
10	0	40 points	410 points
10	10	290 points	290 points

Information

While you are making your own decision you will get no information about your partner's decision. Only after all participants (types) have made their choices in a round you will get information about your partner's choice (0 or 10).

Computer screens

We will now describe the computer screen that you will see in this part of the experiment. A printout has been handed out to you. Please take this in front of you.

The screenshot shows the CREED Experiment interface. At the top left, the user's type is 'B', the round is '1', and earnings for 'deel I', 'deel II', and 'deel III' are shown. The top middle section is for making a decision between '0' and '10', with a 'Bevestiging' button. The top right shows a yellow message box: 'LET OP, een nieuwe ronde is begonnen.'. The bottom section contains three tables for rounds 1-10, 11-20, and 21-30, each with columns for 'ronde', 'partner', 'keuze', and 'verdienste' (with sub-columns for 'zelf' and 'partner').

The screen consists of four parts.

At the top left it gives information about which type you are, the round you are in, and your earnings in this part of the experiment.

At the top right you find a short summary concerning the decision that you have to make.

The top middle part is the one where you have to make your decision. There you have to choose between “0” and “10” by clicking with your mouse on the left side of one of these numbers. Furthermore you have to confirm your decision by clicking on the “confirmation” button. If necessary you will then still be able to change your decision. Finally, at the bottom of the screen you find for each round a summary of the type of your partner in that round, your and your partner’s choice (0 or 10) and the earnings (points) in that round.

If you have any questions at this stage, please raise your hand. After that, the com-

puter will divide all participants into pairs and the allocation of types will be made. Thereafter, part II of the experiment will start.

Note: In this part there will be no practice round.

The following part of the instructions were given only after everybody had finished the second part. What follows are the instructions for part III in the NCC.

Explanation for Part III

As in part I you will be asked to allocate amounts (points) between yourself and another person, with the help of a circle. However, this other person will no longer only be a randomly chosen other participant in the experiment, but concerns also the participant that you were interacting with in part II. You will now be asked to make two decisions involving two circles, one for the participant that you were interacting with in part II and one for a randomly chosen other participant.

During this part you will see the same screen as you did in part I, except that there are now two circles instead of one. Additionally, on the right side of the screen you will receive information about the decisions that were made in your pair in each round in part II. This information will be exactly the same information as you received during part II at the bottom of your screen.

To remind you we will give you a short summary of what you can do with each of the two circles on your screen. Each point on the circle corresponds to a combination of an amount (points) for yourself and an amount (points) for another person. At the top of the circle it says who the “other” is - the one you were interacting with in part II or a randomly chosen other participant. To make your choice you have to click on the circle with the help of your mouse. By using the mouse or with the buttons below the circle you can adjust your choice. You will also see the number of points for yourself and for the other person, which correspond to the chosen point on the circle, at the bottom next to “for myself” and “for the other”.

After you have made your choice you have to click with your mouse on “confirmation”. You will then get a “last chance” to change your choice.

Your earnings from part III will be determined by your own two decisions and the decisions made by the other two participants that you are connected with. These other

participants - the one you were paired with in part II and the randomly chosen other participant - have to make a similar decision.

Your earnings from this part of the experiment will therefore equal the sum of the two amounts that you are allocating to yourself and the amounts that are allocated to you by the two other participants.

Note: An amount can be positive (+), but can also be negative (-). In the latter case the amount will go at the expense of the person that it was meant for.

At the end of this part today's experiment will be finished. You will then receive information about the decisions of the other participants from this part and from part I of the experiment. You will then also see how much you have earned in this experiment.

If you have any questions please raise your hand. After that part III will start.

Note, in this part there will be no practice round.

The following part of the instructions were given only after everybody had finished the first part. What follows are the instructions for part II in the CC.

Explanation for Part II

In this part of the experiment each participant will be in a group of three with two other participants. Each group consists of a "type A", a "type B" and a "type C" participant. The difference between these types is related to the decisions they can make and the earnings that are linked to them. More about that later. Before part II starts, groups will be formed completely randomly with the help of the computer and participants of each group will be labeled as either a type A, B or C. Neither the group of three that you will be part of nor the types will change during this part of the experiment. Which type you are will be announced to you on the computer screen before the start of part II.

Part II consists of 30 rounds. If you are type A you have to make two decisions in each round. If you are type B or C then you only have to make one decision in each round.

Note: During all 30 rounds the other two participants within your group will stay the same persons and the type of a participant will also not change.

Decisions (in a round)

Type A: Type A first has to choose one of the other participants (types) as a partner: type B or type C. Furthermore type A has to choose between the two alternatives “0” and “10”.

Types B and C: Types B and C only have to choose between the two alternatives “0” and “10”.

Earnings

Your earnings within a round will depend on your type and will be determined as follows:

Type A: Your earnings depend on the choice between 0 and 10 that you and the partner chosen by you have made. There are four possibilities:

your choice	partner's choice	your earnings	partner's earnings
0	0	160	160
0	10	410	40
10	0	40	410
10	10	290	290

The participant that is not chosen as a partner will always earn 90 points.

Types B and C: If you are chosen as a partner by type A then your earnings depend on the choices between 0 and 10 by yourself and your partner of type A. There are again four possibilities. They are the same as shown in the table above for type A.

If you are not chosen as a partner by type A you will earn 90 points.

Information

While you are making your own decision you will receive no information on the decisions made by the other two in your group. Only after all participants (types) have made their choices in a round you will get the following information:

Type A: You will only receive information about the choice (0 or 10) of the partner that you chose. You will not get to see the decision of the participant that you did not choose.

Type B and C: You will only receive information if A chose you as a partner. In that case you will only see the choice (0 or 10) that A made.

You will not receive any further information if A didn't choose you as a partner.

Computer screens

We will now describe the computer screen that will you see in this part of the experiment. A printout has been handed out to you. Please take this in front of you.

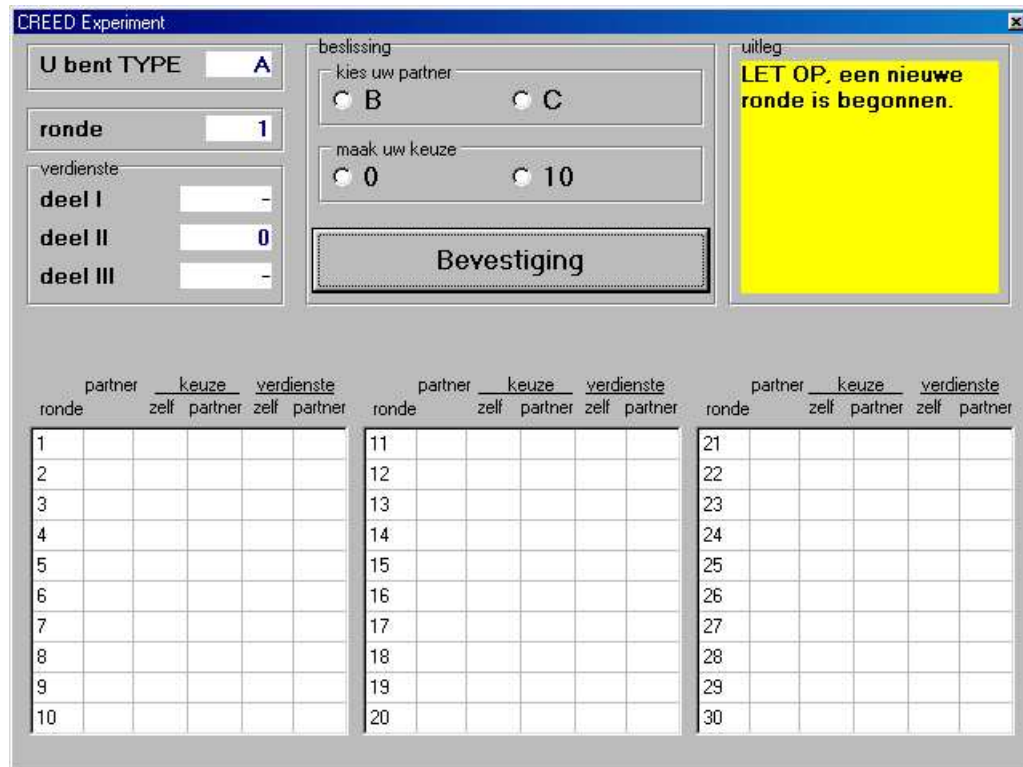

The screen consists of four parts.

At the top left it gives information about which type you are, the round you are in, and your earnings in this part of the experiment.

At the top right you find a short summary concerning the decision that you have to make.

The top middle part is the one where you have to make your decision. If you are a type A you choose your partner - type B or type C - by clicking on the left side of "B" or "C", with the help of the mouse. Then you have to choose between "0" and "10" by clicking to the left side of one of these numbers. If you are a type B or C you only have to make the latter choice. Furthermore you have to confirm your decision by clicking on the "confirmation" button. If necessary you will then still be able to change your decision.

Finally, at the bottom of the screen you find for each round a summary of the type of your partner in that round, your and your partner's choice (0 or 10) and the earnings (points) in that round. If you were not chosen as a partner there will be a ("-") next to "partner", "partner's choice" and "partner's earnings".

If you have any questions at this stage, please raise your hand. After that, the computer will divide all participants into groups of three and the allocation of types will be made. Thereafter, part II of the experiment will start.

Note: In this part there will be no practice round.

The following part of the instructions were given only after everybody had finished the second part. What follows are the instructions for part III in the CC.

Explanation for Part III

As in part I you will be asked to allocate amounts (points) between yourself and another person, with the help of a circle. However this other person will now no longer be a randomly chosen other participant in the experiment, but will be each of the two participants that you interacted with in part II. You will now be asked to make two decisions involving two circles, one for each participant that you interacted with in part II.

During this part you will see the same screen as you did in part I, except that there are now two circles instead of one. Additionally, on the right side of the screen you will receive information about the decisions you and your partner made in each round in part II. This information will be exactly the same information that you received during part II at the bottom of your screen.

To remind you we will give you a short summary of what you can do with each of the two circles on your screen. Each point on the circle corresponds to a combination of an amount (points) for yourself and an amount (points) for another person. At the top of the circle it says of which type - that means which of the two other participants from part II - the "other" is. To make your choice you have to click on the circle with the help of your mouse. By using the mouse or with the buttons below the circle you can adjust your choice. You will also see the number of points for yourself and for the other person, which correspond to the chosen point on the circle, at the bottom next to "for myself" and "for the other".

After you have made your choice you have to click with your mouse on “confirmation”. You will then get a “last chance” to change your choice.

Your earnings from part III will be determined by your own two decisions and the decisions made by the other two participants that you are connected with. These other participants - the same ones you were connected with in part II - have to make a similar decision.

Your earnings from this part of the experiment will therefore equal the sum of the two amounts that you are allocating to yourself and the amounts that are allocated to you by the two other participants (types).

Note: An amount can be positive (+), but can also be negative (-). In the latter case the amount will go at the expense of the person that it was meant for.

At the end of this part today’s experiment will be finished. You will then receive information about the decisions of the other participants from this part and from part I of the experiment. You will then also see how much you have earned in this experiment.

If you have any questions please raise your hand. After that part III will start.

Note, in this part there will be no practice round.

In both conditions, after the second part was finished and before subjects received instructions for the third part they were asked to answer questions concerning their global subjective well-being and their experienced emotions. All questionnaires were computerized and answered on-line.

The question concerning “global subjective well-being”:

How do you feel **at this moment**? Choose with the help of the figure the number that best describes how you feel.

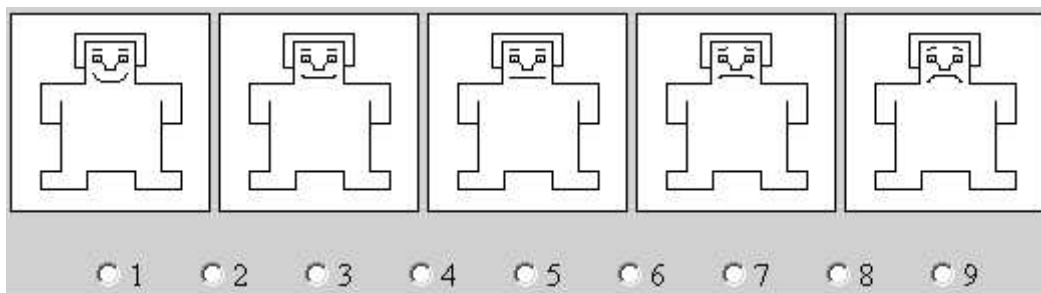

The questions concerning the individual emotions:

We would like to have some more information about how you feel **at this moment**. We ask you to first read the list of emotion-words below. Thereafter, you have to indicate for each of the listed emotions with which intensity you experience it.

sadness	not at all	very intense
happiness	not at all	very intense
shame	not at all	very intense
pride	not at all	very intense
fear	not at all	very intense
envy	not at all	very intense
relief	not at all	very intense
anger	not at all	very intense
joy	not at all	very intense
guilt	not at all	very intense
irritation	not at all	very intense
surprise	not at all	very intense
contempt	not at all	very intense

If you think that one or more other emotion-words describe your experience better than the above ones, then you can - if you wish - name them here together with their intensity:

..... not at all very intense
..... not at all very intense
..... not at all very intense

How do the results of this part of the experiment relate to what you expected?

- ... worse than expected
- ... as expected
- ... better than expected
- ... I did not have expectations